

# Installation Instructions for SESD290 / DESE290 1/4" Semi-Frameless Door and 3/8" 180° and 90° Panel

## FIRST STEPS - Identify the model number of your unit.

- Look on the white shipping label on the outer cardboard box.
- **Model number** on label should correspond to one listed above.

Scan this Barcode for Parts Bag BP.3144.NLT



Pick a unit below that best represents your configuration.

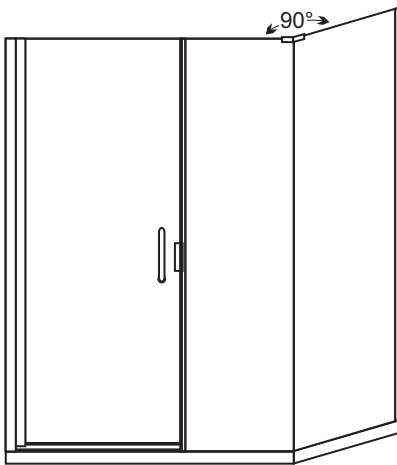

SESD290  
DESD290

Standard Door/Panel  
Pages 3 - 5

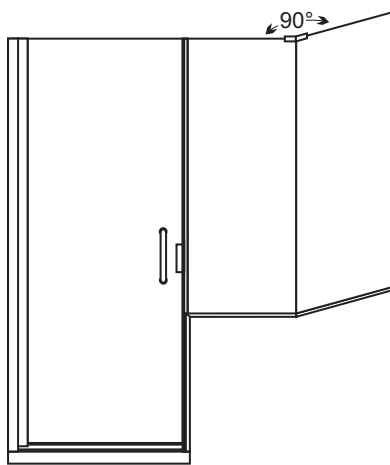

SESD290  
DESD290

with buttress  
Pages 6 - 8

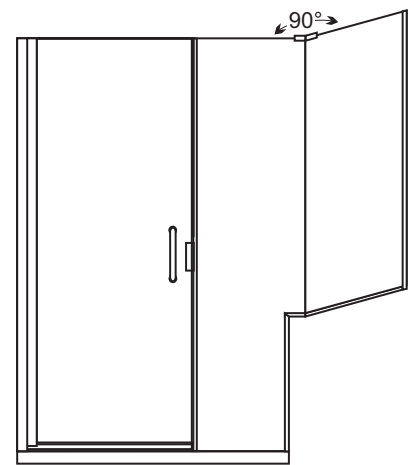

SESD290  
DESD290

with notched panel  
Pages 9 - 11

### NOTE:

- Installation procedures are the same for tub or shower height units
- The images in this manual show an arrangement with the showerhead to the left. The same instructions apply for the opposite orientation where the examples would be reversed.

## Required Tools

\* Pencil or water soluble felt pen

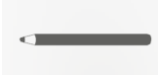

\* Hacksaw with 24 tooth blade

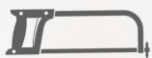

\* Metal file (smooth sharp edges)

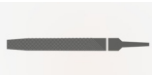

\* Tape measure



\* Clear 100% Silicone (recommended)



\* #2 Phillips Screw driver



\* 1/8", 3/16", 1/4", 3/8" drill bits (carbide for tile)



\* Caulking gun



\* Drill, electric or battery



\* 4 ft. Level



\* Rubber mallet

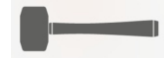

\* Razor knife



P/N MM.5025  
rev061920

# READ ENTIRE MANUAL BEFORE INSTALLATION AND OPERATION

## Warnings and General Shower Door Information



**SAFETY  
WARNINGS:**



**READ AND FOLLOW INSTRUCTIONS:** Failure to follow all instructions, warnings and guidelines may result in serious injury or death, may cause water damage, and will void the terms of your warranty.

## General Safety and Installation Policies

### Before Installation:

- **Proper Size:** Ensure the enclosure is the proper size for your opening prior to beginning installation.
- **Safe Installation:** Some units may require two or more people to safely install the enclosure properly.
- **Packaging:** It is recommended to retain all packaging and other materials until installation is complete in the event of a return.
- **Inspect:** Installer should inventory all parts or components and inspect them for damage prior to beginning installation.
- **Sharp Edges:** Exposed ends of aluminum and other hard components can be rough, sharp or jagged due to the processes of cutting, drilling, notching, etc. Sharp ends must be deburred, smoothed or rounded by the installer before installation.
- **Safety equipment and tools:** Have all necessary safety equipment (glasses and gloves) and proper tools for the installation. The installer is responsible for determining the correct drill bit(s) for the installation.
- **New Tile:** We recommend that you allow at least 2 days (48 hours) for the tile cement and grout to dry before installing enclosure.

### During Installation



- **Proper backing:** Shower doors are heavy. Therefore, glazing channels, fillers, hinges and headers blocks (structural components) should be secured to studs or solid backing beneath the tile or decorative substrate. Fasteners should screw directly into the backing. Wall anchors are provided primarily to separate screws from tile to reduce the possibility of cracking.

- **Tempered glass:** Glass can break. Shower door panels are tempered to ASTM C1048 specifications as required by building codes. Glass is tempered to greatly increase its strength and to make it fragment into smaller and lighter pieces reducing the possibility of injury in the event that the glass does break. Tempered glass will break and may cause bodily injury if you attempt to cut, drill, mill or alter it in any way. Care must be taken when handling tempered glass. Pay special attention to protect all edges of the glass from contact with hard surfaces.
- **Horizontal surfaces and installation holes:** Avoid drilling into the horizontal surfaces of tubs or showers unless it is required for the structural integrity of the unit. If you drill into horizontal surfaces, always generously caulk the holes, anchors, screws and on top of the screw head. If this is not done, or is done improperly, water damage can occur under the tile or substrate.
- **Weep holes in horizontal channels:** Drilling 3/8" weep holes on the inside of horizontal channels is recommended to allow any moisture build-up inside a channel to exit the channel. Due to varying installation conditions and installer's/owner's personal preference, however, we do not drill them in the factory.
- **Sliding and swinging glass doors:** A door may be improperly installed if it hits or scrapes against bathroom obstructions (toilets or cabinets) or any metal or glass components of the shower door itself. This could lead to glass breakage or serious injury. The installer must correct the deficiencies before allowing the door to be used.
- **Surface conditions:** Most shower door designs allow for out-of-square or unlevel installation. Generally, any outage more than 3/8" that was not identified during the ordering process is outside of these allowances and can result in an improper installation.

### Caulking/Siliconing the Unit:

- Always clean all contact surfaces before caulking and use a high grade 100% silicone for best results.
- After installation, at a minimum, caulk the entire outside perimeter of the unit where the unit touches walls, sills, and step-ups, etc. Also caulk any vertical joints between metal components where water build-up inside of the channels could leak out.

### After Installation:

- **Curing times:** Adhere to manufacturers' recommended curing times for VHB tapes, silicones and any other adhesives, coatings or chemicals used during installation. Unless otherwise stated, it is recommended to wait 72 hours before using the enclosure.
- **Normal wear and tear:** Although these enclosures are designed to last for years, certain items (such as the polycarbonate seals and door sweeps) may need to be replaced as they show signs of aging and wear.

## General Disclaimers

- **Shower Doors are not watertight:** Consumers should understand that a shower door is not watertight. The amount of water that can escape your shower can vary greatly based on shower/tub size, configuration of shower head(s), type of thresholds and drains and by the type of shower door itself. Heavy glass units with no or limited vinyl seals, for example, can allow water to escape under normal conditions. Doors with more metal and seals generally provide more water protection. Excessive water pressure or directing shower heads or hand held sprays directly at doors or joints is not a normal shower conditions and can result in leaks.
- **Towel bars, handles and accessories** are in no way considered to be grab bars or other bracing or fall prevention mechanisms. The intent of these accessories is to facilitate proper operation or enhance the esthetics and functionality of the unit.

## Owners Manual:

Refer to your Owners Manual for general installation and cleaning and care instructions. If a copy of the Owners Manual was not included, you can download one on the RESOURCES page of our website.

## Questions or Comments:

1-800-843-3332

# Installation Instructions

## Models: **SESD290, DESD290 or MESD290**

### 1/4" Semi-Frameless Door and 3/8" In-Line & 90 Panel

Figure 1 - Exploded View

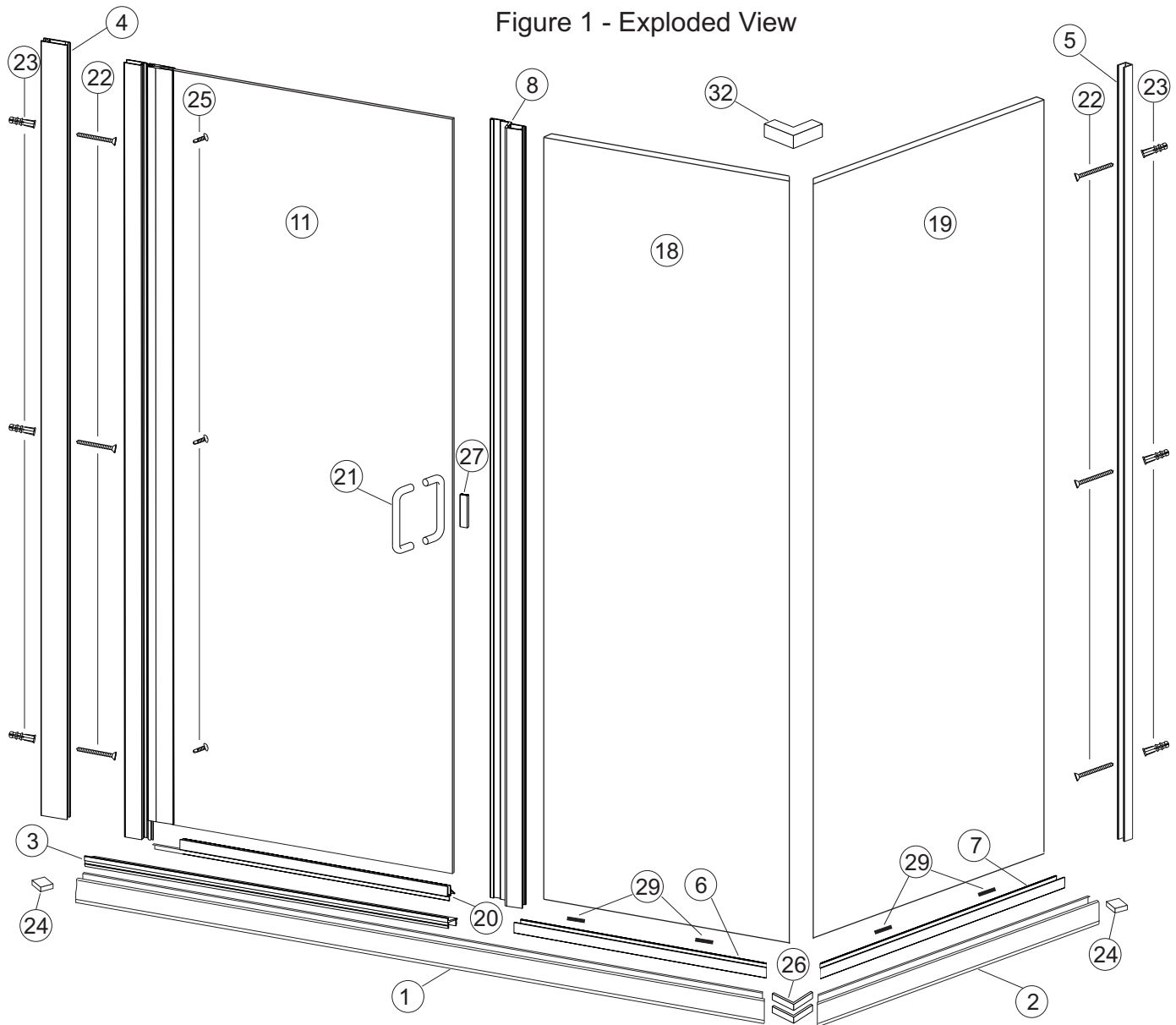

### Parts List

- |  |   |  |
|--|---|--|
| <ul style="list-style-type: none"> <li>1. EX.1022 - Stall Curb LS 45° - 1</li> <li>2. EX.1022 - Stall Curb RS 45° - 1</li> <li>3. EX.1025 - Curb Filer - 1</li> <li>4. EX.1268 - Hinge Wall Channel - 1</li> <li>5. EX.1018 - Panel Wall Channel - 1</li> <li>6. EX.1018 - Panel Sill LS 45° - 1</li> <li>7. EX.1018 - Panel Sill RS 45° - 1</li> <li>8.- 10. Clear-Poly Latch Assembly</li> <li>11. - 17. Door Assembly - 1</li> <li>18. 3/8 Fixed Panel - 1</li> <li>19. 3/8 Fixed Panel - 1</li> <li>20. VN.4062 - PVC Drip Deflector - 1</li> <li>21. HA.2701 - D-pull Handle - 1</li> </ul> | <ul style="list-style-type: none"> <li>22. SP.2101 - #8 X 1-1/2 FHPHMS - 6</li> <li>23. SP.2217 - 3/16 X 7/8 Wall Anchor - 6</li> <li>24. SP.2204 - Foam Plug - 2</li> <li>25. SP.2110 - #8 X 1/2 PPHP TEK - 3</li> <li>26. SP.2015 - 90° Curb Clips - 2</li> <li>27. - BP.3701 - Magnetic Edge Cap Assembly</li> <li>29. BP.3028 - Setting Block Kit</li> <li>30. SP.2221 - Centering Clip - 5</li> <li>31. VN.4031 - Snap Dry Glaze Vinyl</li> <li>32. HA.2667 - Sleeve Over Clamp</li> </ul> | <ul style="list-style-type: none"> <li>11. Door Assembly-EX.1165-Hinge Jamb-1</li> <li>12. VN.4034 - Hinge Sleeve - 1</li> <li>13. EX.1466 - Hinge Rail - 1</li> <li>14. SP.2200 - Hinge Pin - 2</li> <li>15. SP.2181 - Flat Washer - 2</li> <li>16. SP.2123 - #6 X 1/2 PPHP MS - 2</li> <li>17. 1/4 Clear Door Glass - 1</li> </ul> |
|--|---|--|

**Boxed information is assembly detail.**

*Extra screws may be provided for your convenience*

# Installation Instructions

Models: SESD290, DESD290 or MESD290

1/4" Semi-Frameless Door and 3/8" In-Line & 90° Panel

## STEP 1 - Curb Installation (#1 & #2)

- \* Measure the wall to intersection, then intersection to back wall. This is where the center of the unit will be installed. Mark location for reference.\*
- \* Add 1/2" to each measurement and cut Stall Curbs #1 and #2 to length measuring from the long point of the miters.
- \* Insert foam plug #24 into each end of the Stall Curb and recess 1/8".
- \* Fill 1/8" void with silicone. Insert 2 - #26 corner clips and silicone the miter.
- \* Set the curb in place centered over where you measured, secure with blue tape.
- \* Be sure weep holes are to inside of shower.

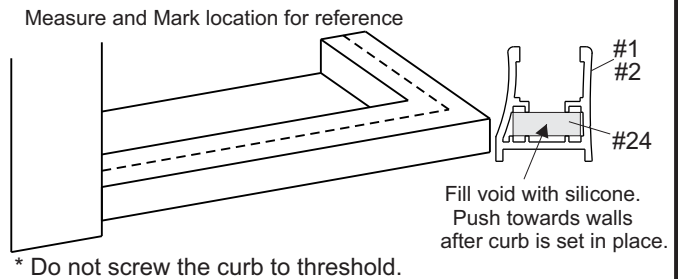

\* Do not screw the curb to threshold.

## STEP 2 - Wall Channel (#5)

- \* Insert Wall Channel #5 into curb, on side of fixed panel.
- \* Plumb channel with a level.
- \* Mark the hole locations onto the wall.
- \* Remove the channel.
- \* Drill marked locations with 3/16" drill bit
- \* Insert 3 - Wall Anchors #23 (may have to razor heads of anchors flush to wall).
- Re-insert channel and secure with 3 - #22 screws.

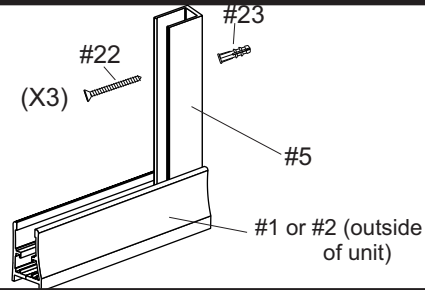

## STEP 3 - Panel Sill (#6 #7) 3/8" Fixed Panels (#18 #19)

- \* Measure width of 3/8" Fixed Panel (#19) 90° panel and subtract 3/16".
- \* Cut the Panel Sill #7, to this length measuring from the long point of the miter.
- \* Measure width of 3/8" Fixed Panel (#18) inline panel and add 3/16".
- \* Cut the Panel Sill #6, to this length measuring from the long point of the miter.
- \* Set the Panel Sills #6 & #7 into the Stall Curb #1 and butt to the Wall Channel #5.
- \* Insert two Setting Blocks #29 into each Panel Sill.

**Wet Glaze Option Only** - If using silicone to bond the glass to the wall channel and panel sills:

- Install 2 - #30 Centering Clips evenly spaced into each Panel Sill, offset from Setting Blocks.
- Insert 3 - #30 Centering Clips into the Wall channel.

**Dry Glaze Option** - If using push-in glazing vinyl to set the 3/8" glass panel, do not use Centering Clips #30.

- \* Set 3/8" 90° Glass Panel into Panel Sill and Wall Channel.
- \* Adjust glass edge to to the mitered end of Panel Sill #7.
- \* Adjust top of glass flush to top of Wall Channel, place additional setting blocks under glass if needed.
- \* Ensure vertical edge of 3/8" Glass Panel is plumb.
- \* Set 3/8" inline Glass Panel into Panel Sill.
- \* Adjust top of glass flush to top of 1st panel. Place additional setting blocks under glass if needed.
- \* Ensure leading edge of 3/8" Glass Panel is plumb.
- \* See page 12 for instructions on siliconging the panels together.

**Wet Glaze Option** - Temporarily, but securely fix Glass Panels into position with blue painter's tape.

**Dry Glaze Option** - Holding the glass panels in position, roll or press the Glazing Bead into both sides of sill and wall channel using a roller or smooth block of wood.

- \* Check to ensure panel didn't move.

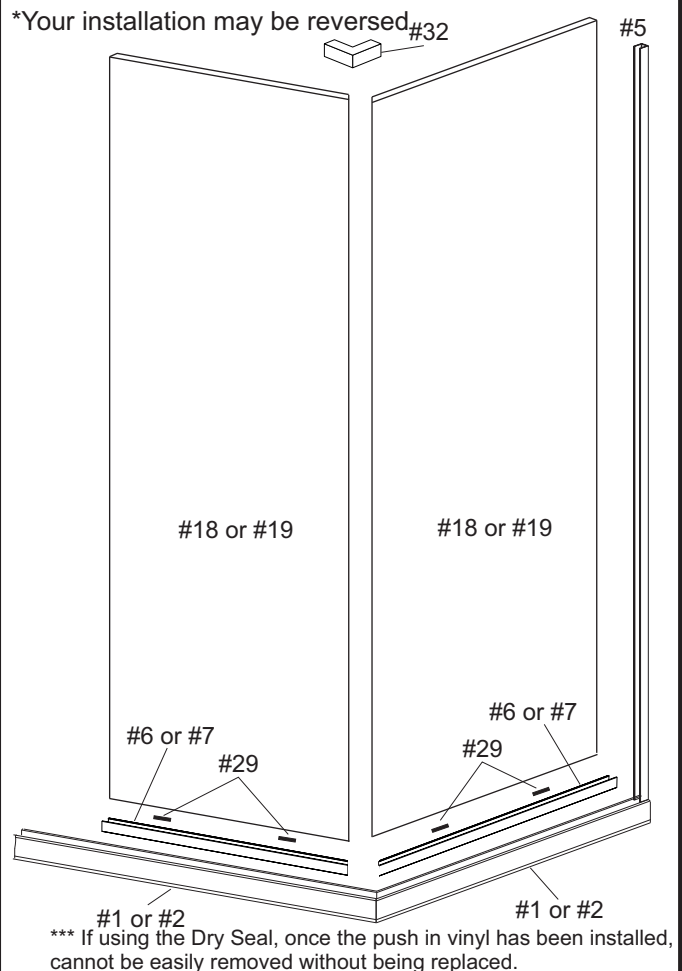

## STEP 4 - Curb Filler (#3)

- \* Measure from the edge of the 3/8" Glass Panel to the Door side wall. Cut the Curb Filler #3 to this length.
- \* With the two forks pointing down and the vertical leg to the front of the unit, snap the Curb Filler into the Stall Curb.
- \* The slope of the Curb filler should be to the inside of the shower.

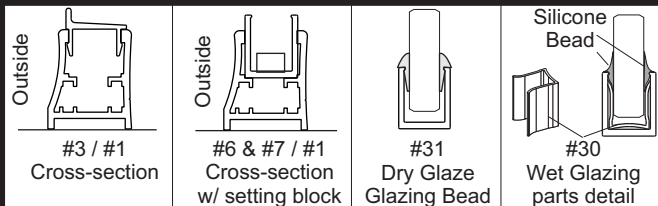

### STEP 5 - Clear-Poly Latch Jamb (#8)

- \* Measure from top of 3/8" Glass Panel #18 to top of the sloped surface of the Curb Filler #3.
- \* Take Clear-Poly Latch Jamb assembly, and remove the Bulb Seal and Strike Plate, set aside for later step.
- \* Cut Clear-Poly Latch #8 to above dimension using a 24 tooth hatch-saw. Power saw may damage latch
- \* Recommended: notch the Clear-Poly Latch at bottom to clear the Panel Sill #6 (trim legs up 3/16").
- \* Apply the Clear-Poly Latch Jamb on edge of Glass with latch inside unit ensuring it is flush with the top of the Fixed panel.

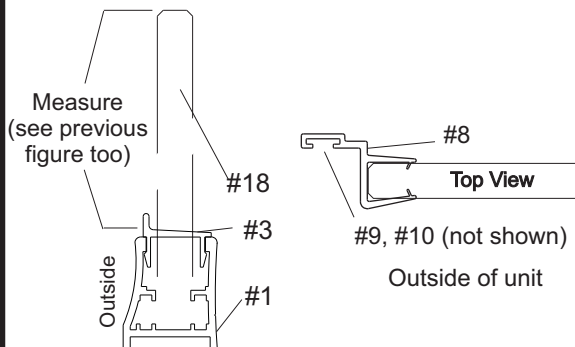

### STEP 6 - Attach Door-Side Wall Channel (#4)

- \* Set door-side Wall Channel #4 in place against the door side wall, on top of the Curb Filler.
- \* Gap the bottom of the wall channel 1/16" from the vertical water dam of the Curb Filler (This will allow the room for the Door assembly to slide over.)
- \* Plumb Wall Channel, mark the hole locations on wall and remove Wall Channel.
- \* Drill holes with 3/16" bit, insert 3 - #23 Wall Anchors, re-install Wall channel and secure with 3 - #22 Screws.

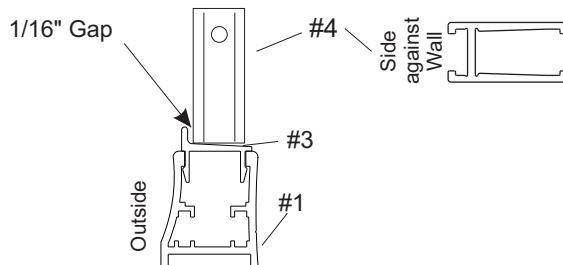

### STEP 7 - Door Assembly / Pre-Hanging Prep

- \* Attach Pull - Handle #21 to Door.
- \* Dry run the position of Magnetic Catch Assembly, #27, #28 and mark location with marker on glass.
- \* Apply small bead of silicone inside Catch Assembly and work onto edge of glass at mark. Let silicone dry.

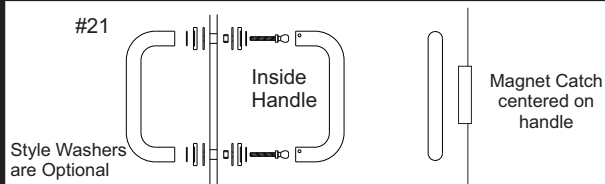

### STEP 8 - Hang Door Assembly

- \* Slide door assembly over the Wall Channel (Step 6)
- \* Adjust door until top edge of the door is level and flush with top of 3/8" Glass Panel.
- \* Also ensure door-to-latch gap is consistent from bottom to top.
- \* When aligned, secure Door Assembly to Wall Channel with 3 - #25 screws using factory pilot holes in the Hinge Jamb.

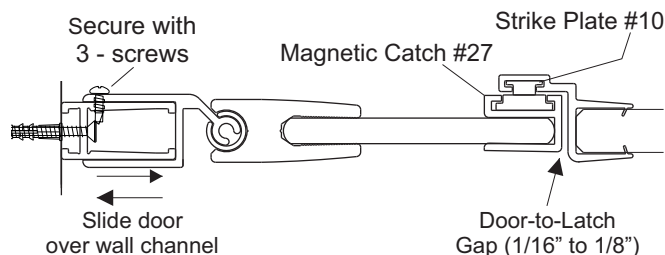

### Finish Latch

- \* Temporarily slide Strike Plate #10 into Clear-Poly Latch #8, align with Mag Catch #27.
- \* Mark top and bottom of Strike Plate onto Latch.
- \* Marks and cut Bulb Seal #9 to proper length.
- \* From top of latch, re-insert bottom bulb seal, strike and top seal. Dabs of silicone may be required to secure Bulb Seals and Strike in place. Hold with Painters tape while drying.

### STEP 9 - Bottom Sweep Fitting (#20)

- \* Measure the Door Glass including Hinge Rail.
- \* Subtract 1/16" and cut the Bottom sweep to this length. IMPORTANT: The sweep is notch on both ends. You must leave the notch that goes under the Hinge Rail for your door. Cut off the end with the notch you don't need.
- \* Trim the inside deflector 3/8" so it will clear the Latch Jamb when door is closed.

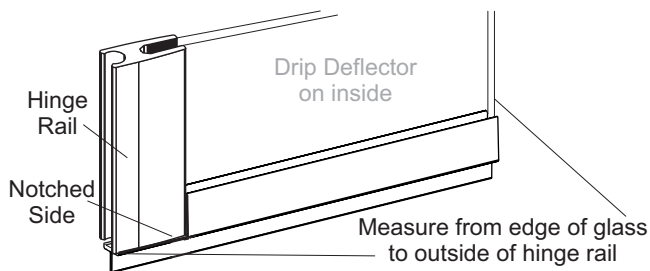

### STEP 10 - Final Sealing / Siliconging the Unit (let dry for 24 hours before use)

- \* On the outside of the unit, run a bead of silicone down both walls and across the bottom where the metal meets the walls and base.
- \* Apply a dab of silicone at the bottom of the latch jamb where it meets the Curb Filler.

# Installation Instructions

## Models: SESD290, DESD290 or MESD290 Buttress 1/4" Semi-Frameless Door and 3/8" In-Line & 90 Panel

Figure 1 - Exploded View

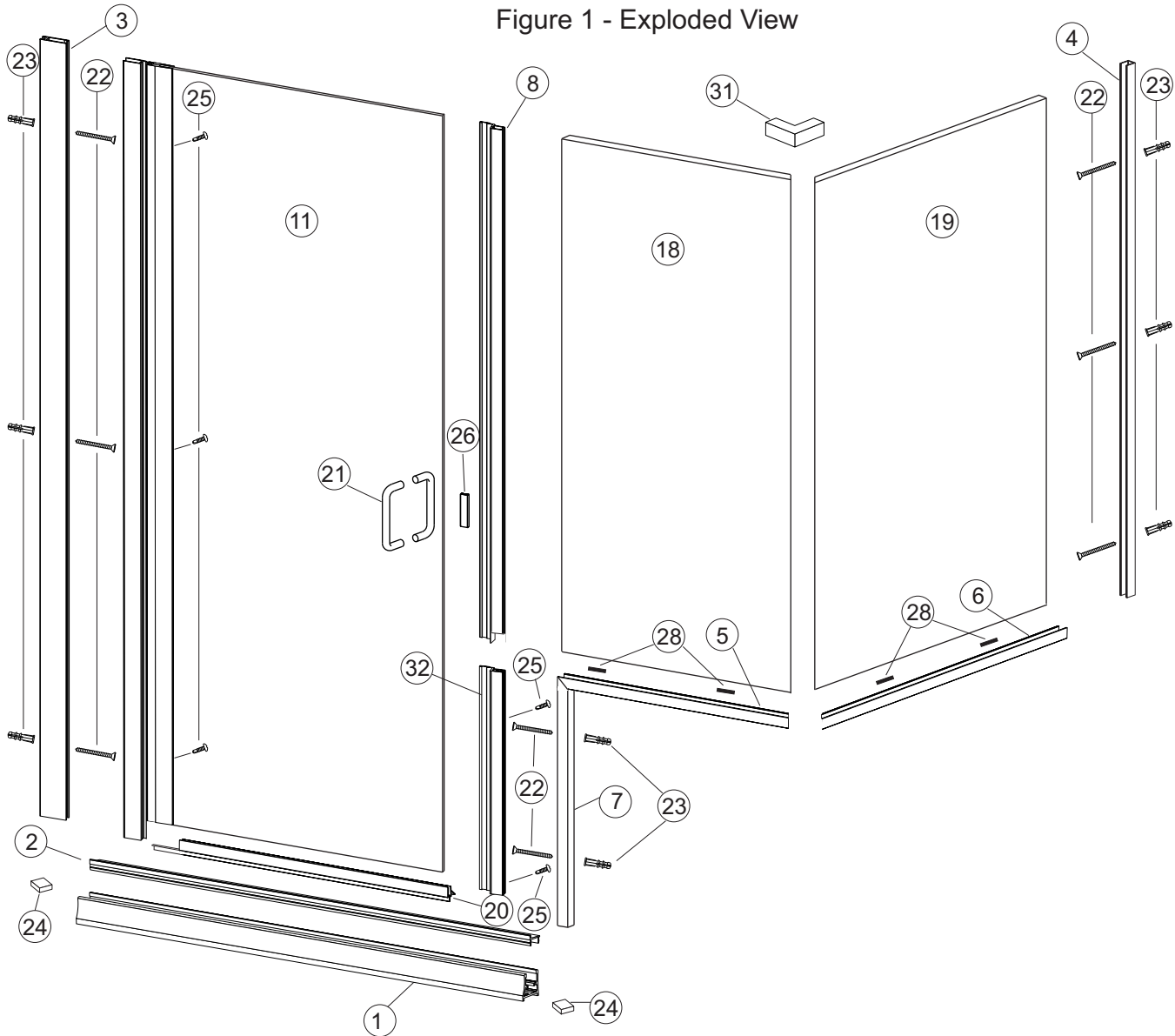

### Parts List

- |  |  |  |
|--|--|--|
| <ul style="list-style-type: none"> <li>1. EX.1022 - Stall Curb - 1</li> <li>2. EX.1025 - Curb Filer - 1</li> <li>3. EX.1268 - Hinge Wall Channel - 1</li> <li>4. EX.1018 - Panel Wall Channel - 1</li> <li>5. EX.1018 - Panel Sill LS 45° - 1</li> <li>6. EX.1018 - Panel Sill RS 45° - 1</li> <li>7. EX.1018 - Panel Sill Vertical - 1</li> <li>8.- 10. Clear-Poly Latch Assembly</li> <li>11.- 17. Door Assembly - 1</li> <li>18. 3/8 Fixed Panel in-line - 1</li> <li>19. 3/8 Fixed Panel 90° - 1</li> <li>20. VN.4062 - PVC Drip Deflector - 1</li> <li>21. HA.2701 - D-pull Handle - 1</li> </ul> | <ul style="list-style-type: none"> <li>22. SP.2101 - #8 X 1-1/2 FHPHMSMS - 8</li> <li>23. SP.2217 - 3/16 X 7/8 Wall Anchor - 8</li> <li>24. SP.2204 - Foam Plug - 2</li> <li>25. SP.2110 - #8 X 1/2 PHPH TEK - 6</li> <li>26. BP.3701 - Magnetic Edge Cap Assembly</li> <li>28. BP.3028 - Setting Block Kit</li> <li>29. SP.2221 - Centering Clip -5</li> <li>30. VN.4031 - Snap Dry Glaze Vinyl</li> <li>31. HA.2667 - Sleeve Over Clamp</li> <li>32. VN.4076 - Buttress PVC Latch - 1</li> </ul> | <ul style="list-style-type: none"> <li>11. Door Assembly-EX.1165-Hinge Jamb-1</li> <li>12. VN.4034 - Hinge Sleeve - 1</li> <li>13. EX.1466 - Hinge Rail - 1</li> <li>14. SP.2200 - Hinge Pin - 2</li> <li>15. SP.2181 - Flat Washer - 2</li> <li>16. SP.2123 - #6 X 1/2 PHPH MS - 2</li> <li>17. 1/4 Clear Door Glass - 1</li> </ul> |
|--|--|--|
- 8. Clear Poly Latch-VN.4075-PVC Latch - 1
  - 9. VN.4002 - Bulb Seal - 1
  - 10. SP.2194 - Strike Plate - 1

**Boxed information is assembly detail.**

*Extra screws may be provided  
for your convenience*

# Installation Instructions

Models: SESD290, DESD290 or MESD290 Buttress  
1/4" Semi-Frameless Door and 3/8" In-Line & 90° Panel

## STEP 1 - Curb Installation (#1 & #2)

- \* Measure the dimensions as shown at right. This is where the center of the unit will be installed. Mark location for reference.
- \* Subtract 1/16" from dimension A and cut Stall Curb #1.
- \* Insert foam plug #24 into each end of the Stall Curb and recess 1/8".
- \* Fill 1/8" void with silicone.
- \* Set the curb in place centered over where you measured, secure with blue tape.
- \* Be sure weep holes are to inside of shower.

Measure and Mark location for reference

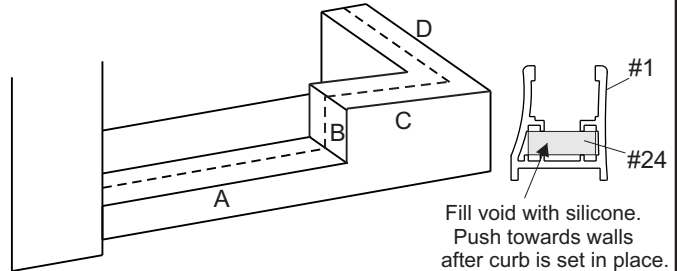

\* Do not screw the curb to threshold.

## STEP 2 - Curb Filler (#2)

- \* Measure and cut the Curb Filler #2 to the same length as the Stall Curb.
- \* With the two forks pointing down and the vertical leg to the front of the unit, snap the Curb Filler into the Stall Curb.
- \* The slope of the Curb filler should be to the inside of the shower. Tape the curb down to hold it in place.

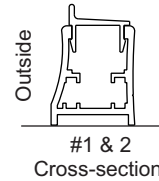

## STEP 3 - Panel Sills (5, 6, 7)

- \* If Panel Sills are not already cut to size, cut them as follows:  
#7 = Dim B minus 1/2" , leave the miter.  
#5 = Dim C + 1 1/16", cut to dim measuring from longest point of both miters. You will have to reproduce one of the miters.  
#6 = Dim D + 5/16", leave the miter.
- \* With the Stall Curb already in place, dry set the three Panel Sills, aligning them to the opening and each other. Mark their locations and secure them with Blue Tape.
- \* Set Wall Channel #4, on top of the Panel Sill #6. Plumb with a level and mark the hole locations onto the wall.
- \* Drill marked holes with a 3/16" drill bit. Insert 3 - #23 Wall Anchors, and secure with 3 - #22 Screws.

**Wet Glaze Option Only** - If using silicone to bond the glass to the wall channel and panel sills:

- Install 2 - #29 Centering Clips evenly spaced into each Panel Sill.
- Insert 3 - #29 Centering Clips into the Wall channel.

**Dry Glaze Option** - If using push-in glazing vinyl to set the 3/8" glass panel, do not use Centering Clips #29.

- \* Insert 2 - #28 Setting blocks and set 3/8" Fixed Panel #19 into the Panel Sill and Wall Channel.
- \* Using Setting Blocks, adjust Fixed Panel so that it is flush with the top of the Wall Channel and the leading edge of panel is plumb.
- \* Insert 2 - #28 Setting blocks and set 3/8" Fixed Panel #18 into the Panel Sill. Leave a 1/16" to 1/8" gap between the Fixed panels and adjust panel flush with top of 1st panel and the leading edge is plumb.
- Use the Sleeve over Clamp #31 to help stabilize the panels.
- \* See page 12 for instructions on siliconing the panels together.

**Wet Glaze Option** - Temporarily, but securely fix Glass Panels into position with blue painter's tape.

**Dry Glaze Option** - Holding the glass panels in position, roll or press the Glazing Bead into both sides of sill and wall channel using a roller or smooth block of wood.

- \* Check to ensure panel didn't move.

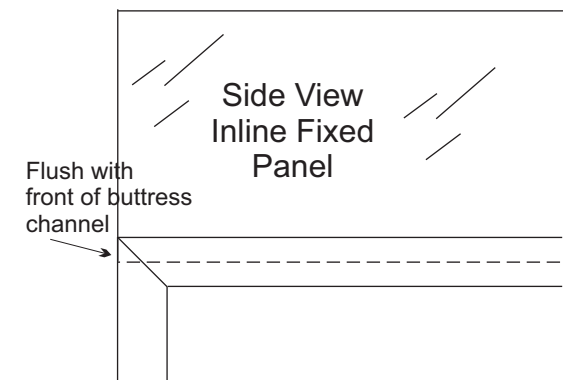
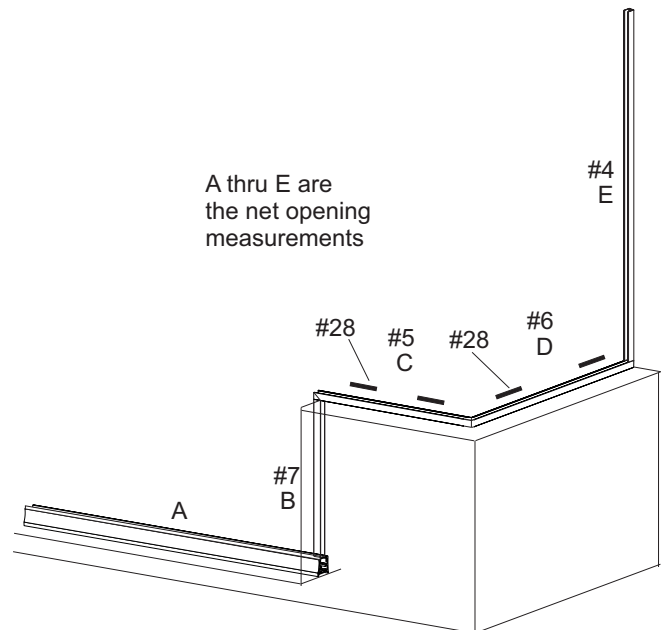

\*\*\* If using the Dry Seal, once the push in vinyl has been installed, it cannot be easily removed without being replaced.

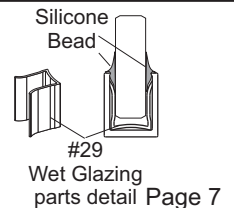
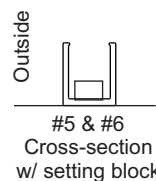

#### STEP 4 - Clear-Poly Latch Jamb (#8)

- \* Measure from top of 3/8" Glass Panel #18 to top of the Panel Sill #5. Add 3/4" to this measurement.
- \* Take Clear-Poly Latch Jamb assembly, and remove the Bulb Seal and Strike Plate, set aside for later step.
- \* Cut Clear-Poly Latch #8 to above dimension using a 24 tooth hatch-saw. Power saw may damage latch.
- \* Notch the Clear-Poly Latch at bottom to clear the Panel Sill #5 (trim legs up 3/4").
- \* Apply the Clear-Poly Latch Jamb on edge of Glass with latch inside unit ensuring it is flush with the top of the Fixed panel.
- \* Measure from the bottom of the upper PVC latch down to the top of the sloped surface of the Curb filler and cut the #32 Buttress PVC Latch the that dimension.
- \* Insert Buttress PVC Latch into the #7 channel and butt to the bottom of the top Latch. They will act as one latch jamb.

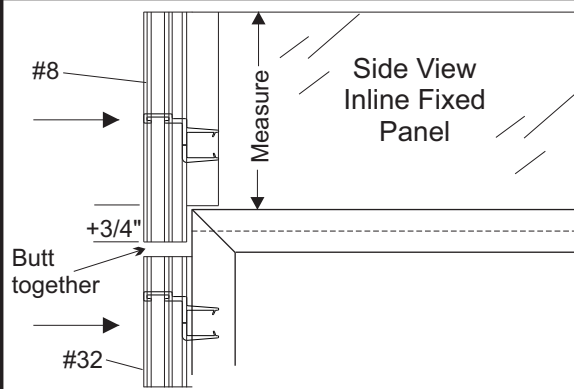

#### STEP 5 - Attach Door-Side Wall Channel (#3)

- \* Set door-side Wall Channel #3 in place against the door side wall, on top of the Curb Filler.
- \* Gap the bottom of the wall channel 1/16" from the vertical water dam of the Curb Filler (This will allow the room for the Door assembly to slide over.)
- \* Plumb Wall Channel, mark the hole locations on wall and remove Wall Channel.
- \* Drill holes with 3/16" bit, insert 3 - #23 Wall Anchors, re-install Wall channel and secure with 3 - #22 Screws.

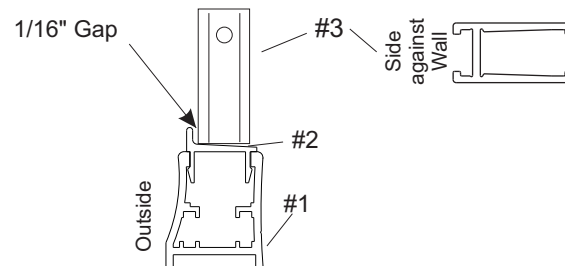

#### STEP 6 - Door Assembly / Pre-Hanging Prep

- \* Attach Pull - Handle #21 to Door.
- \* Dry run the position of Magnetic Catch Assembly, #26, #27 and mark location with marker on glass.
- \* Apply small bead of silicone inside Catch Assembly and work onto edge of glass at mark. Let silicone dry.

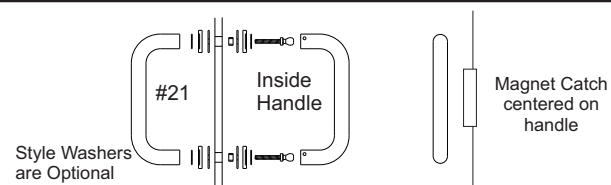

#### STEP 7 - Hang Door Assembly

- \* Slide door assembly over the Wall Channel (Step 5)
- \* Adjust door until top edge of the door is level and flush with top of 3/8" Glass Panel.
- \* Also ensure door-to-latch gap is consistent from bottom to top.
- \* When aligned, secure Door Assembly to Wall Channel with 3 - #25 screws using factory pilot holes in the Hinge Jamb.

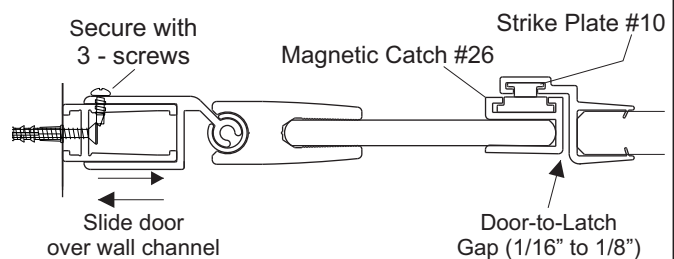

#### Finish Latch

- \* Temporarily slide Strike Plate #10 into Clear-Poly Latch #8, align with Mag Catch #26.
- \* Mark top and bottom of Strike Plate onto Latch.
- \* Marks and cut Bulb Seal #9 to proper length.
- \* From top of latch, re-insert bottom bulb seal, strike and top seal. Dabs of silicone may be required to secure Bulb Seals and Strike in place. Hold with Blue tape while drying.
- \* Secure #32 lower PVC latch from the inside with 2 - # 8 X 1/2 PHPH TEK screws.

#### STEP 8 - Bottom Sweep Fitting (#20)

- \* Measure the Door Glass including Hinge Rail.
- \* Subtract 1/16" and cut the Bottom sweep to this length. IMPORTANT: The sweep is notch on both ends. You must leave the notch that goes under the Hinge Rail for your door. Cut off the end with the notch you don't need.
- \* Trim the inside deflector 3/8" so it will clear the Latch Jamb when door is closed.

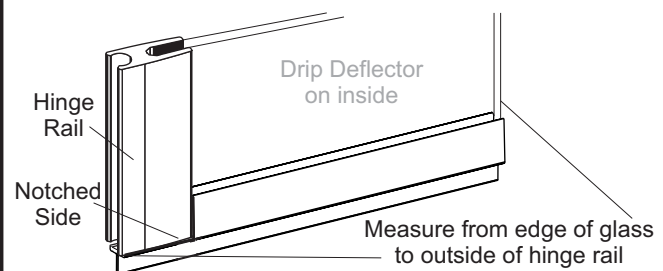

#### STEP 9 - Final Sealing / Siliconing the Unit (let dry for 24 hours before use)

- \* On the outside of the unit, run a bead of silicone down both walls and across the bottom where the metal meets the walls and base.
- \* Apply a dab of silicone at the bottom of the latch jamb where it meets the Curb Filler.



# Installation Instructions

**Models: SESD290, DESD290 or MESD290 Notched Panel and Buttress**  
 1/4" Semi-Frameless Door and 3/8" In-Line & 90 Panel

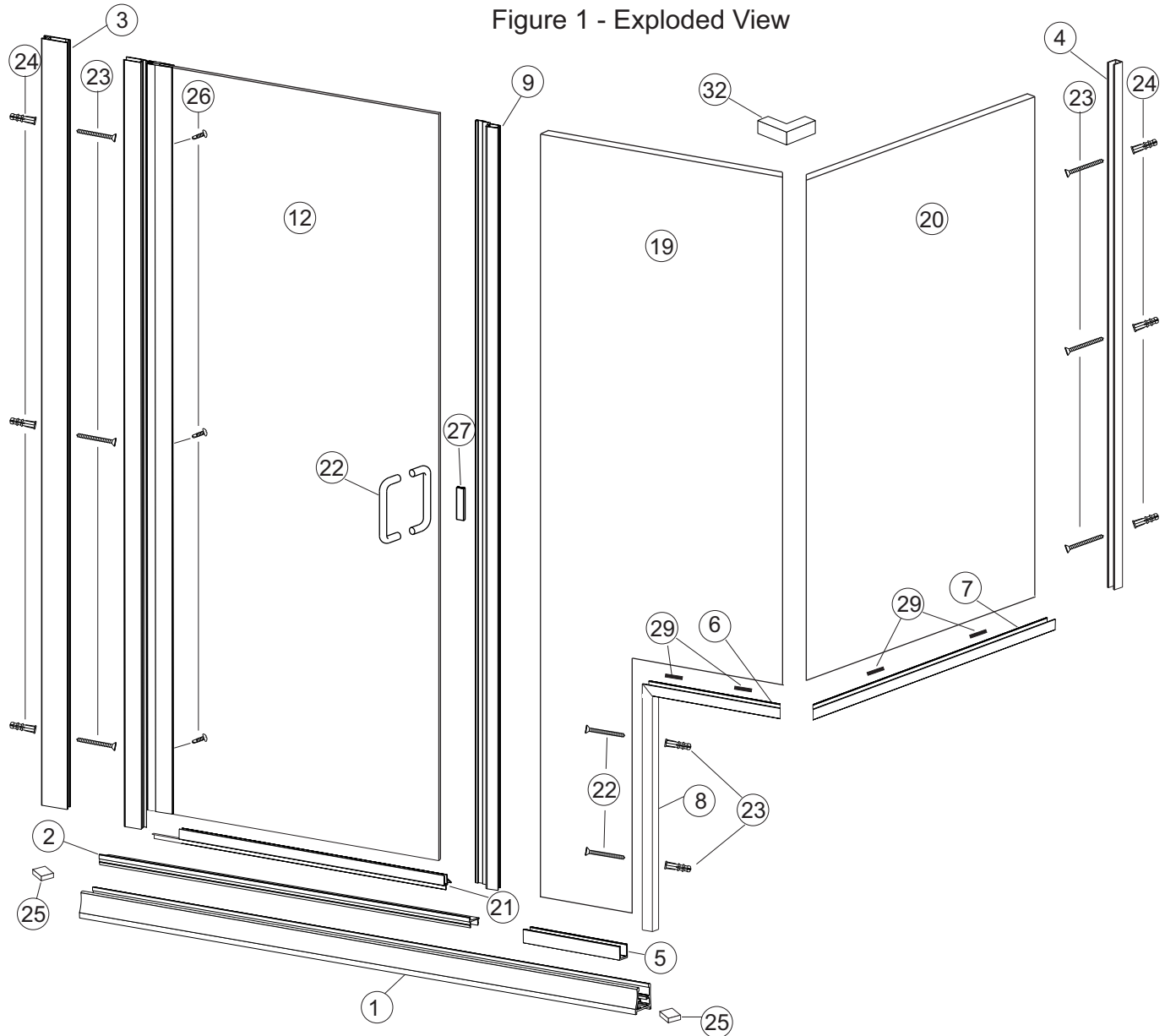

Figure 1 - Exploded View

## Parts List

- |  |  |   |
|--|--|---|
| <ul style="list-style-type: none"> <li>1. EX.1022 - Stall Curb - 1</li> <li>2. EX.1025 - Curb Filer - 1</li> <li>3. EX.1268 - Hinge Wall Channel - 1</li> <li>4. EX.1018 - Panel Wall Channel - 1</li> <li>5. EX.1018 - Panel Sill Lower - 1</li> <li>6. EX.1018 - Panel Sill LS 45° - 1</li> <li>7. EX.1018 - Panel Sill RS 45° - 1</li> <li>8. EX.1018 - Panel Sill Vertical - 1</li> <li>9.- 11. Clear-Poly Latch Assembly</li> <li>12.- 18. Door Assembly - 1</li> <li>19. 3/8 Fixed Panel inline - 1</li> <li>20. 3/8 Fixed Panel 90° - 1</li> <li>21. VN.4062 - PVC Drip Deflector - 1</li> <li>22. HA.2701 - D-pull Handle - 1</li> </ul> | <ul style="list-style-type: none"> <li>23. SP.2101 - #8 X 1-1/2 FHPHMS - 8</li> <li>24. SP.2217 - 3/16 X 7/8 Wall Anchor - 8</li> <li>25. SP.2204 - Foam Plug - 2</li> <li>26. SP.2110 - #8 X 1/2 PPH TEK - 3</li> <li>27. BP.3701 - Magnetic Edge Cap Assembly</li> <li>29. BP.3028 - Setting Block Kit</li> <li>30. SP.2221 - Centering Clip - 5</li> <li>31. VN.4031 - Snap Dry Glaze Vinyl</li> <li>32. HA.2667 - Sleeve Over Clamp</li> </ul> | <ul style="list-style-type: none"> <li>12. Door Assembly-EX.1165-Hinge Jamb-1</li> <li>12. VN.4034 - Hinge Sleeve - 1</li> <li>13. EX.1466 - Hinge Rail - 1</li> <li>14. SP.2200 - Hinge Pin - 2</li> <li>15. SP.2181 - Flat Washer - 2</li> <li>16. SP.2123 - #6 X 1/2 PPH MS - 2</li> <li>18. 1/4 Clear Door Glass - 1</li> </ul> |
|--|--|---|
- 9. Clear Poly Latch-VN.4075-PVC Latch - 1
  - 10. VN.4002 - Bulb Seal - 1
  - 11. SP.2194 - Strike Plate - 1

**Boxed information is assembly detail.**

*Extra screws may be provided for your convenience*

# Installation Instructions

Models: SESD290, DESD290 or MESD290 Notched Panel and Buttress  
1/4" Semi-Frameless Door and 3/8" In-Line & 90° Panel

## STEP 1 - Curb Installation (#1)

- \* Measure the dimensions as shown at right. This is where the center of the unit will be installed. Mark location for reference.
- \* Subtract 1/16" from dimension A and cut Stall Curb #1.
- \* Insert foam plug #25 into each end of the Stall Curb and recess 1/8".
- \* Fill 1/8" void with silicone.
- \* Set the curb in place centered over where you measured, secure with blue tape.
- \* Be sure weep holes are to inside of shower.

Measure and Mark location for reference

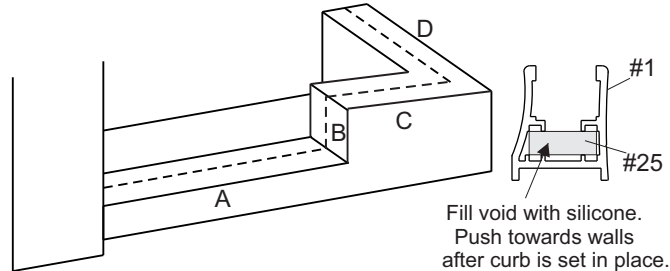

\* Do not screw the curb to threshold.

## STEP 2 - Panel Sills (6, 7, 8)

- \* If Panel Sills are not already cut to size, cut them as follows:  
#8 = Dim B + 1/8", leave the miter. Vertical sill sets inside of Stall Curb #1.  
#6 = Dim C + 1 1/16", cut to dim measuring from longest point of both miters. You will have to reproduce one of the miters.  
#7 = Dim D + 5/16", leave the miter.
- \* With the Stall Curb already in place, dry set the three Panel Sills, aligning them to the opening and each other. Mark their locations and secure them with Blue Tape.
- \* Set Wall Channel #4, on top of the Panel Sill #7. Plumb with a level and mark the hole locations onto the wall.
- \* Drill marked holes with a 3/16" drill bit. Insert 3 - #24 Wall Anchors, and secure with 3 - #23 Screws.

**Wet Glaze Option Only** - If using silicone to bond the glass to the wall channel and panel sills:

- Install 2 - #30 Centering Clips evenly spaced into each Panel Sill.
- Insert 3 - #30 Centering Clips into the Wall channel.

**Dry Glaze Option** - If using push-in glazing vinyl to set the 3/8" glass panel, do not use Centering Clips #30.

- \* Insert 2 - #29 Setting blocks and set 3/8" Fixed Panel #20 into the Panel Sill and Wall Channel.
- \* Using Setting Blocks, adjust Fixed Panel so that it is flush with the top of the Wall Channel and the leading edge of panel is plumb. Measure the width of the lower leg of the notched panel. Subtract 3/8" and cut the lower Panel Sill #5 to the dimension. Insert the Panel Sill #5 into the Stall Curb and butt it up to the vertical Panel Sill #8.
- \* Insert 4 - #29 Setting blocks and set 3/8" Fixed Panel #19 into the Panel Sill. Leave a 1/16" to 1/8" gap between the Fixed panels and adjust panel flush with top of 1st panel and the leading edge is plumb.
- Use the Sleeve over Clamp #32 to help stabilize the panels.
- \* See page 12 for instructions on siliconing the panels together.

**Wet Glaze Option** - Temporarily, but securely fix Glass Panels into position with blue painter's tape.

**Dry Glaze Option** - Holding the glass panels in position, roll or press the Glazing Bead into both sides of sill and wall channel using a roller or smooth block of wood.

- \* Check to ensure panel didn't move.

A thru E are the net opening measurements

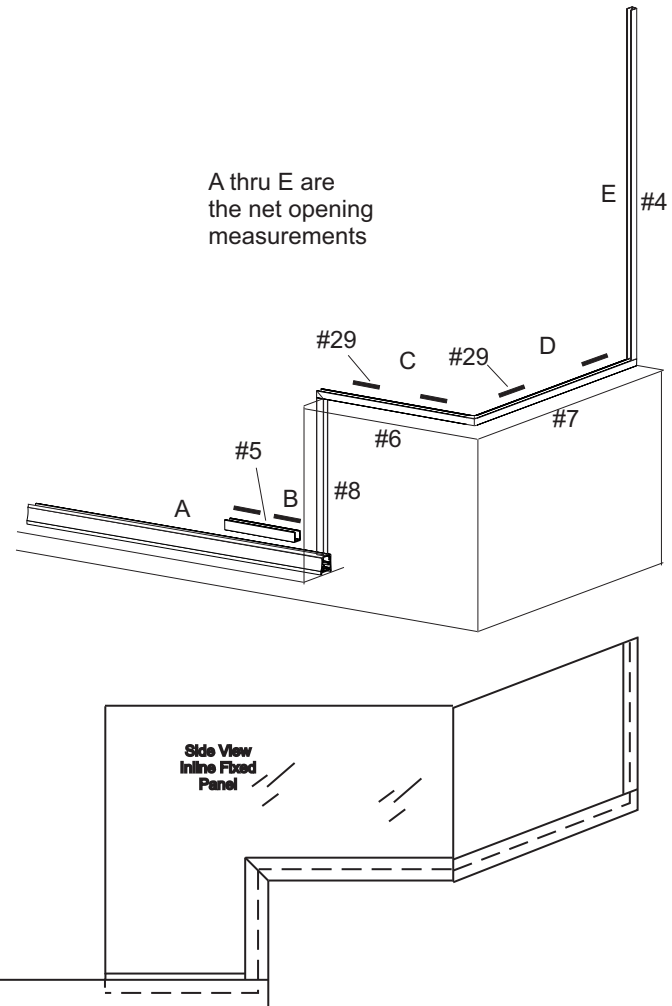

\*\*\* If using the Dry Seal, once the push in vinyl has been installed, it cannot be easily removed without being replaced.

## STEP 3 - Curb Filler (#2)

- \* Measure between the door wall and the leading edge of the 3/8" In-line notched panel.
- \* Cut the Curb Filler #2 to this length. It will fit between the wall and the Panel Sill of the inline panel.
- \* With the two forks pointing down and the vertical leg to the front of the unit, snap the Curb Filler into the Stall Curb.
- \* The slope of the Curb filler should be to the inside of the shower. Tape the curb down to hold it in place.

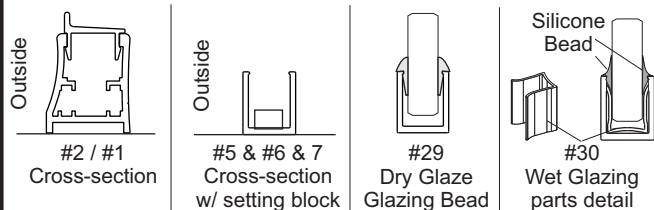

### STEP 5 - Clear-Poly Latch Jamb (#9)

- \* Measure from top of 3/8" Glass Panel #19 to top of the sloped surface of the Curb Filler #2.
  - \* Take Clear-Poly Latch Jamb assembly, and remove the Bulb Seal and Strike Plate, set aside for later step.
  - \* Cut Clear-Poly Latch #9 to above dimension using a 24 tooth hatch-saw. Power saw may damage latch.
- Recommended: notch the Clear-Poly Latch at bottom to clear the Panel Sill #5 (trim legs up 3/16").
- \* Apply the Clear-Poly Latch Jamb on edge of Glass with latch inside unit ensuring it is flush with the top of the Fixed panel.

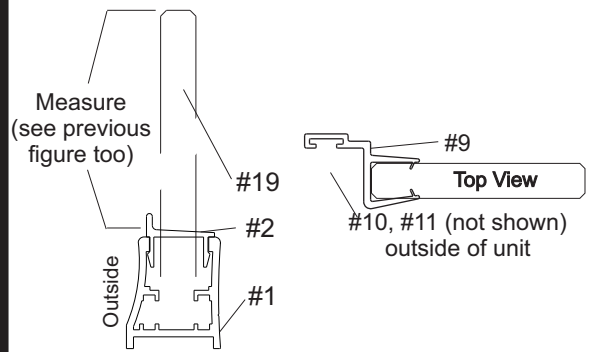

### STEP 6 - Attach Door-Side Wall Channel (#3)

- \* Set door-side Wall Channel #3 in place against the door side wall, on top of the Curb Filler.
- \* Gap the bottom of the wall channel 1/16" from the vertical water dam of the Curb Filler (This will allow the room for the Door assembly to slide over.)
- \* Plumb Wall Channel, mark the hole locations on wall and remove Wall Channel.
- \* Drill holes with 3/16" bit, insert 3 - #24 Wall Anchors, re-install Wall channel and secure with 3 - #23 Screws.

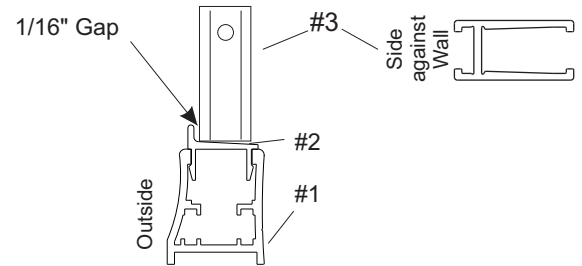

### STEP 7 - Door Assembly / Pre-Hanging Prep

- \* Attach Pull - Handle #22 to Door.
- \* Dry run the position of Magnetic Catch Assembly, #27, #28 and mark location with marker on glass.
- \* Apply small bead of silicone inside Catch Assembly and work onto edge of glass at mark. Let silicone dry.

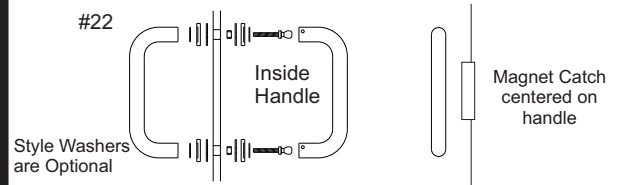

### STEP 8 - Hang Door Assembly

- \* Slide door assembly over the Wall Channel (Step 6).
- \* Adjust door until top edge of the door is level and flush with top of 3/8" Glass Panel.
- \* Also ensure door-to-latch gap is consistent from bottom to top.
- \* When aligned, secure Door Assembly to Wall Channel with 3 - #26 screws using factory pilot holes in the Hinge Jamb.

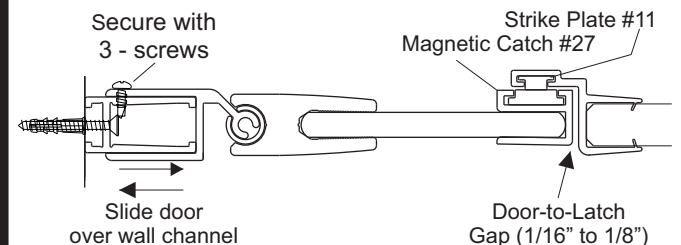

### Finish Latch

- \* Temporarily slide Strike Plate #11 into Clear-Poly Latch #6, align with Mag Catch #27.
- \* Mark top and bottom of Strike Plate onto Latch.
- \* Marks and cut Bulb Seal #10 to proper length.
- \* From top of latch, re-insert bottom bulb seal, strike and top seal. Dabs of silicone may be required to secure Bulb Seals and Strike in place. Hold with Painters tape while drying.

### STEP 8 - Bottom Sweep Fitting (#21)

- \* Measure the Door Glass including Hinge Rail.
  - \* Subtract 1/16" and cut the Bottom sweep to this length.
- IMPORTANT:** The sweep is notched on both ends. You must leave the notch that goes under the Hinge Rail for your door. Cut off the end with the notch you don't need.
- \* Trim the inside deflector 3/8" so it will clear the Latch Jamb when door is closed.

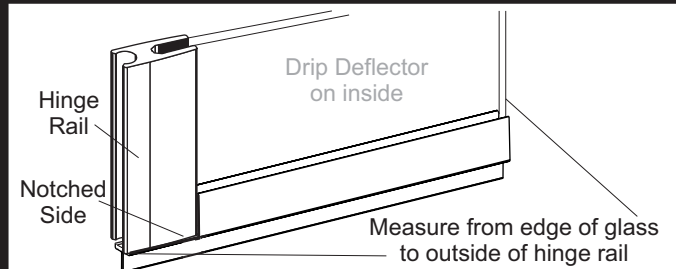

### STEP 10 - Final Sealing / Siliconing the Unit (let dry for 24 hours before use)

- \* On the outside of the unit, run a bead of silicone down both walls and across the bottom where the metal meets the walls and base.
- \* Apply a dab of silicone at the bottom of the latch jamb where it meets the Curb Filler.

# Installation Instructions

## Siliconing Glass-to-Glass Joints

1. Both pieces of glass must be free of grease and other contaminants for best silicone adhesion and strongest joint.
2. Make sure that both pieces are in their final positions, with even gap and sight lines. Temporarily secure panels using tape or other devices to stabilize panels as pressure is applied to the joint during caulking.
3. Using 2" (best) wide low adhesion painters or transfer tape, tape off both sides of the joint on the inside and outside.
4. Begin sealing the joint from the inside of the shower. You will use the inside corner to help guide the caulking gun. Start at the top and work your way down. The silicone must flow into the joint completely filling the void with excess silicone coming out on the outside of the joint. Any air pockets left in the joint will be visible if not removed.
5. From the inside of the shower, remove the excess silicone from both sides of the joint. Begin "tooling" the silicone by continually running a finger or similar tool down the joint on the inside and outside until the joint is uniform and smooth. Final tooling is done with a wet finger or tool. This will help feather out the joint.
6. Before the silicone gets tacky, carefully remove the tape taking care not to get silicone on the surface of the glass panels. Let silicone cure for 24 hours for maximum adhesion and strength.

TAPE ON OUTSIDE OF JOINT NOT SHOWN

