

1/4" SERIES FRAMLESS NEO-ANGLE CORNER SHOWER WITH STEP PANEL

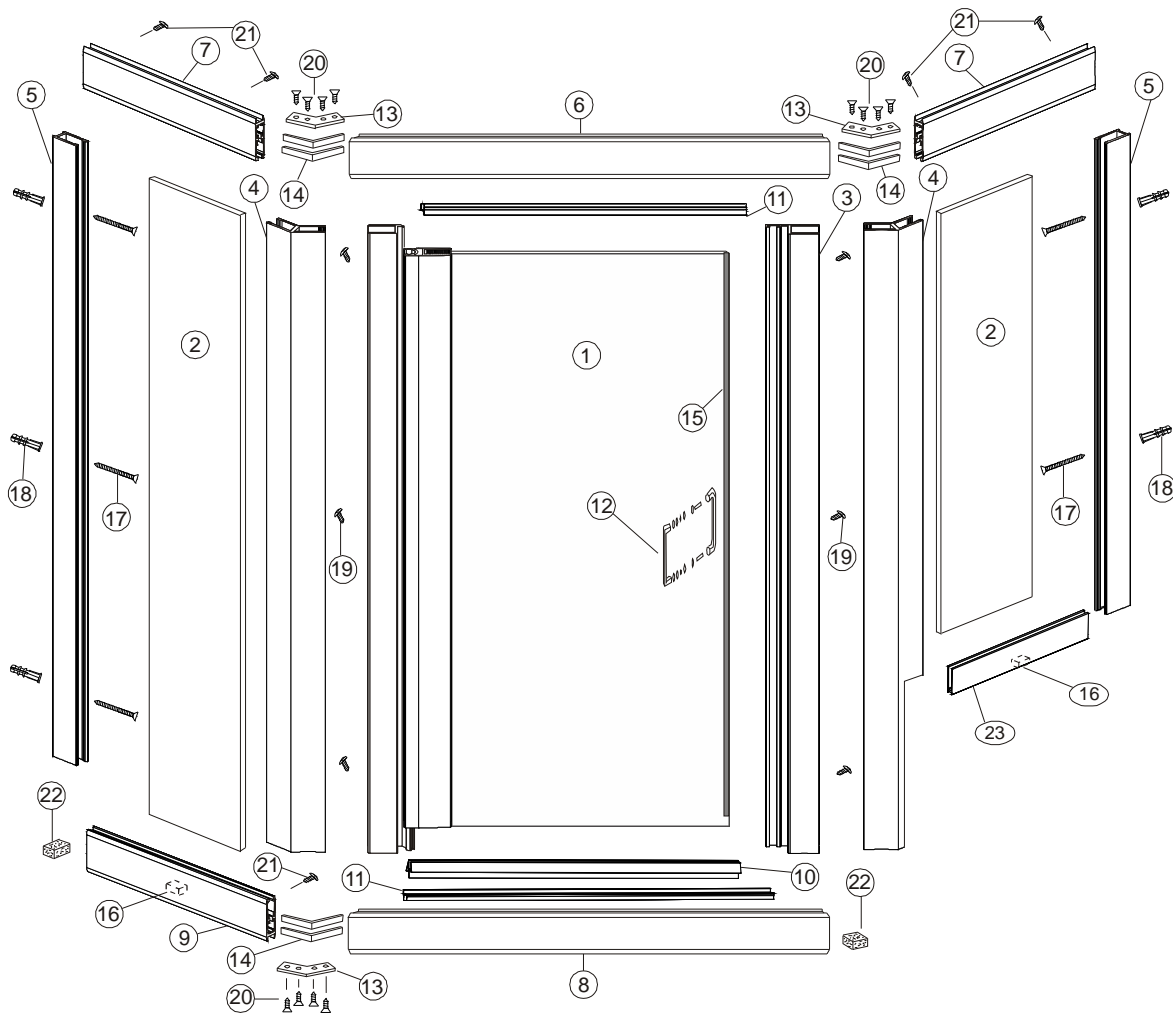

CAT#:	PART LIST:	LENGTH:	QTY:
①	DOOR ASSEMBLY		1
②	PANELS		2
③	1193 STRIKE JAMB & Mag.		1
④	1175 135° CORNER POST		2
⑤	1268 WALL CHANNEL		2
⑥	1171 DOOR STALL HEADER		1
⑦	1171 PANEL STALL HEADER		2
⑧	1271 DOOR STALL CURB		1
⑨	1271 PANEL STALL CURB		1
⑩	4062 1/4" DRIP RAIL		1
⑪	1072 CURB FILLER		2

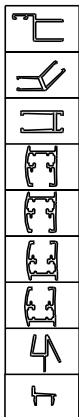

HARDWARE PACK: QTY:

⑫	6" HANDLE TO HANDLE	1
⑬	2018 HEADER PLATE	3
⑭	2017 HEADER CLIP	6
⑮	4102 ADHESIVE MAGNET	1
⑯	2203 SETTING BLOCKS	4
⑰	2101 #8X1-1/2" FHPHMS	6
⑱	2217 WALL ANCHORS	6
⑲	2110 #8X1/2" PPHH TEK	6
⑳	2103 #6X3/8" FHPHMS	12
㉑	2102 #6X3/8" PPHSMS	6
㉒	2204 FOAM PLUG	2
㉓	1070 PANEL SILL	1
㉔	4025 VS-13 THIN VINYL	8
㉕	4026 VS-14 THICK VINYL	8

TOOLS REQUIRED FOR P/J/P316 REV INSTALLATION

- | | |
|---------------------------------------------|----------------------------------------|
| 1. Caulking gun & approved silicone sealant | 6. 3/16" drill bit for plastic anchors |
| 2. Rubber Mallet | 7. 3/16" carbide drill bit for tile |
| 3. Hacksaw | 8. C-clamp or strong spring clamp |
| 4. Phillips Screwdriver | 9. Drill & 1/8" Drill Bit |
| 5. Mill file to smooth cut edges or radius | 10. Level |

1. The curb sections may have already been cut to size at the factory. If not, measure the centerline distance of the door and return panel on the threshold and add 3/16" to each measurement. Measure from the longest point of the miter and cut the square end of the curb. Insert one foam plug into each square cut end. Recess about 1/8" and fill recess with sealant. Assemble curb sections with two curb clips and a header plate. With the corners tight, mark the holes in the plate onto the curb, drill with a 1/8" bit and secure the plate to the header with #6x3/8" flat head screws. Position curb sections onto the base. Seal the mitered corners with sealant and readjust alignment if necessary. Insert a setting blocks into the curb where the glass panel will set, glass should never set on the metal curb.

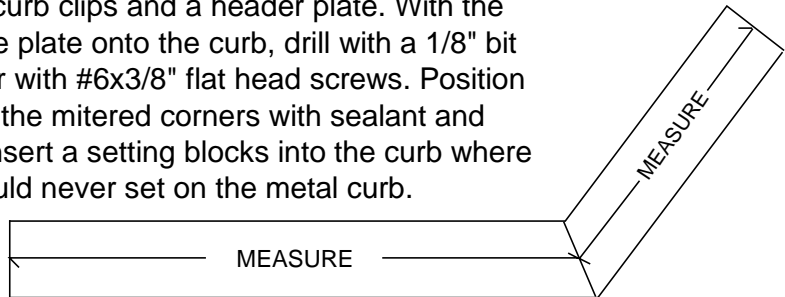

2. Place the full height wall channel into the curb, against the wall and plumb with a level. Mark the mounting holes and remove the channel. Drill 3/16" holes and insert the wall anchors. Use a carbide bit for tile or masonry applications. Secure the channel to the wall with a #8x1-1/2" flat head screws.

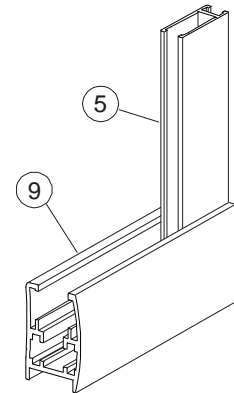

3. Insert the notched 135° corner post (#4) into the curb at the step wall and plumb. Line up the buttress wall channel (#5) directly across from the corner post. Plumb the wall channel and mark the mounting hole locations. Drill 3/16" holes and insert anchors. Secure the wall channel to the wall with #8x1-1/2" flat head screws. Position the panel sill (#23) to fit into the wall channel and into corner post, about 3/8" into each channel. Remove the corner post and place 2 setting blocks into the sill. Place the glass panel into the wall channel and sill. If the panel is textured or has a design on it, make sure that the correct side is facing out. Secure the glass temporarily by inserting about 1 to 2" of the thin vinyl between the glass and wall channel, on each side of the glass. Do not cut the vinyl at this time. Replace the corner post into the curb and over the edge of the glass. Adjust the glass to penetrate both of the vertical channels evenly. Insert the thin vinyl between the glass and metal on the 135° post about 1 to 2". Do not cut the vinyl at this time.

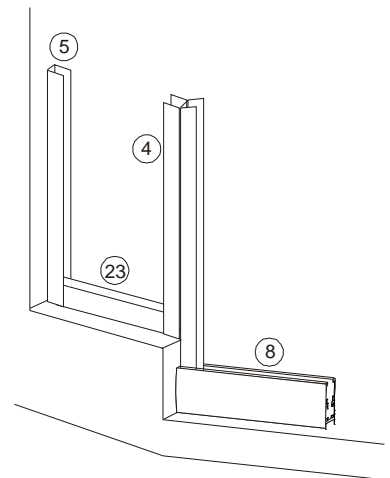

4. Place the return panel glass into the wall channel and sill, on top of the setting blocks. If the panel is textured or has a design on it make sure that the correct side is facing out. Insert 1 to 2" of the thin vinyl between the glass and wall channel on both sides of the glass. Do not cut the vinyl at this time. Place the corner post into the sill and over the edge of the glass. Insert 1 to 2" of vinyl between the glass and metal to temporarily hold the post in place.

5. Using a level, plumb each of the 135° corner posts. Measure from the outside of the corner post to the wall in each direction. Add 1/16" to each dimension. Cut the appropriate header for each return panel measuring from the longest point and cutting from the square end. Measure from the outside of each corner post for the door header, and add 1/8" to that dimension. Cut the door header to that dimension and duplicate the factory miter on the other end. Assemble the header sections with 4 header clips and 2 header plates. Making sure that the miters are tight mark the holes in the plate onto the top of the header. Drill the holes with a 1/8" drill bit. Secure the plate onto the headers with 8 #6x3/8" flat head screws.

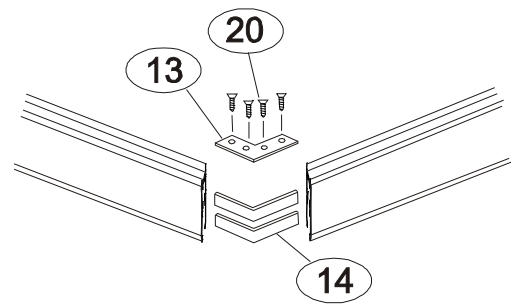

6. Set headers in place over the top of the vertical posts. From the inside of the shower, attach the headers by drilling through the headers into the verticals with a 1/8" drill bit. Make sure to avoid the glass panels while drilling. The bottom of the 135° posts should be secured in the same manner. Once the header is in place, install the thin vinyl into the wall jambs first, then the corner posts. Install the thick vinyl between the glass, the header and the curb. On the step sill, seal the bottom of the panel with silicone on the inside and outside.

7. Place the strike jamb (#3) over the vertical post of your choice, do not secure at this time. Orient the door so that it can open outwards and slide it over the remaining post. Adjust the door and strike so that they are equally off of their respective posts. Adjust the hinge jamb so that the top of the door is parallel with the bottom of the header. From the inside of the shower, drill the top hole through the hinge jamb into the vertical post with a 1/8" drill bit. Secure the jamb with a #8x1/2" pan head TEK screw. Recheck door alignment and repeat the procedure for the middle and bottom screws. Assemble the handle through the holes in the glass with the bushings and shims provided.

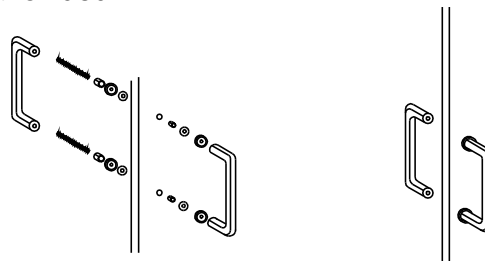

8. Clean the door glass on the inside with a good quality glass cleanser, the adhesion of the magnet will depend on how clean the glass is. Measure the door glass from the top to the bottom and cut the magnet to fit, making sure to have square cuts on the ends. Peel the backing off of the magnet and apply to the glass on the inside of the door, making sure to keep the magnet straight and even along the edge. The adhesive will attain maximum strength in 72 hours, but the door may be used during this time.

9. Adjust the strike jamb to the door assembly. Center the magnets on each other. If the magnets repel each other, remove the strike jamb, and slide the magnet out, turn end for end and insert back into the jamb. Replace the jamb and adjust to work with the magnet on the door. Once adjusted correctly, from the inside of the shower, drill the top hole into the strike jamb and vertical post with a 1/8" drill bit. Secure the jamb with a #8x1/2" pan head TEK screw. Recheck alignment and repeat the procedure for the middle and bottom screws.

10. With the door in closed position, measure between the hinge jamb and strike jamb at the top of the stall curb. Cut one curb filler (#11) to this length. Snap the filler into place in the curb with the vertical water dam to the outside of the shower. Seal each end with sealant. Repeat this step for the header filler. The top filler does not require sealant.

11. To install the drip rail on the bottom of the door, measure the glass at the bottom of the door on the inside between the magnet and hinge jamb. The slanted portion of the drip rail goes on the inside of the shower. If necessary notch the portion of the drip rail so that it will fit under the hinge rail. Test fit and make sure that the drip rail does not interfere with the magnet. Place a few drops of silicone inside of the channel of the drip rail and press upwards onto the bottom of the door.

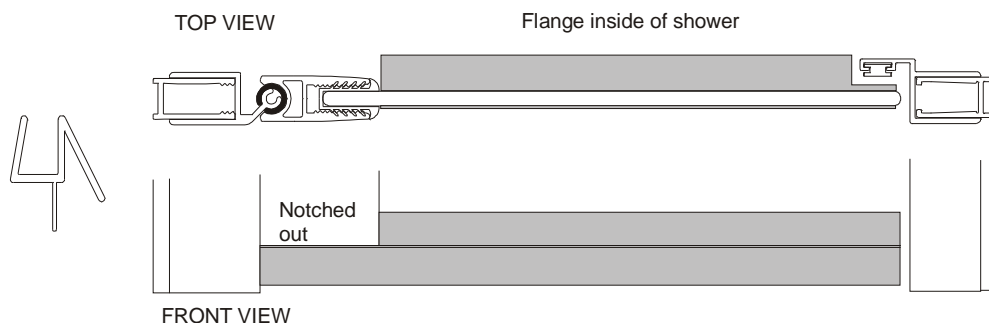

12. Run a continuous bead of silicone across the outside of the shower unit where the metal meets the walls and threshold.

NOTE; For installation and technical support please reference the shipping document, the box that the product was shipped in or call the store where you purchased this product.